

MODULAR LINEAR WEIGHER

LH PACKAGING BV
http://www.lhpackaging.nl

MODULAR LINEAR WEIGHER



Modular Linear Weigher

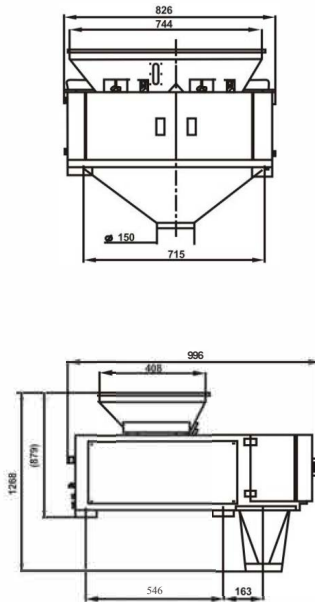

Application

It is suitable for weighing slice, roll or regular shape products such as sugar, salt, seed, rice, sesame, glutamate, milk powder, coffee and season powder, etc.

Mechanical Character

1. Sanitation with 304S/5 construction;
2. Rigid design for vibrator and feed pan make feeding strictly correct;
3. Quick Release design for all the contact parts.

Features

1. Grand new modular control system.
2. Adopt stepless vibrating feeding system to make products flow more fluently.
3. Make mix different products weighing at one discharge.
4. Parameter can be freely adjusted according to production.

Technical Specification

Model	LH-1L8.0	LH-2L8.0	LH-4L0.5	LH-4L1.0	LH-4L3.0	LH-8L0.5
Max.Cap.(9)	259N30009	209NS0009	SN10009	10-10009	209N20009	3N3009*n
Wei9hin9 Accuracy	±19NS9	±19NS9	±0,2N29	±0.2-29	±0,29N29	±0,1N19
Wei9hin9 Speed	10N15WPM	10N30WPM	8SWPM	10-S0WPM	10NS0WPM	170 times/min
Hopper Capacity	8.0L	8.0L	0.5L	1000ml	3.0L	0.5L
Control System	MCU	MCU	MCU	MCU	MCU	MCU
Operation Panel	7 inch touch screen	7inch touch screen	7 inch touch screen	7 inch touch screen	7 inch touch screen	7 touch screen TFT LCD
Power Supply	AC220V±10%50HZ,0.8KW	AC220V±10%50HZ,0.8KW	AC220V±10%50HZ, 1KW	AQ20V±10%50HZ, 1KW	AQ20V±10%50HZ, 1KW	AQ20V±10%50HZ,1KW
Packin9 Dimension	1100(L)*1200(W)*1115(H)	1100(L)*1200(W)*1115(H)	1100(L)*1200(W)*1115(H)	1500(L)*1200(W)*1115(H)	1100(L)*1200(W)*1115(H)	1100(L)*1200(W)*1115(H)
Gross Wei9ht	210k9	230k9	160k9	235k9	235k9	235k9
Optional Devices	Dimple plate/ Teflon paint					
Remark	Above technical data not for final confirmation, there may be variations depend on your special products					