

2ND G STANDARD MULTIHEAD WEIGHER

LH PACKAGING BV
http://www.lhpackaging.nl

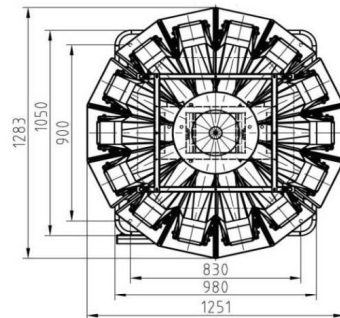

2nd G Standard Multihead Weigher

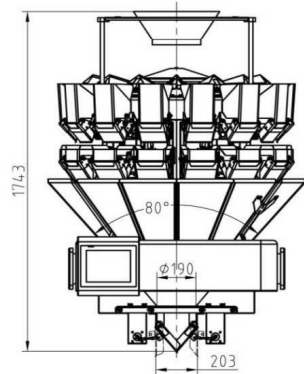
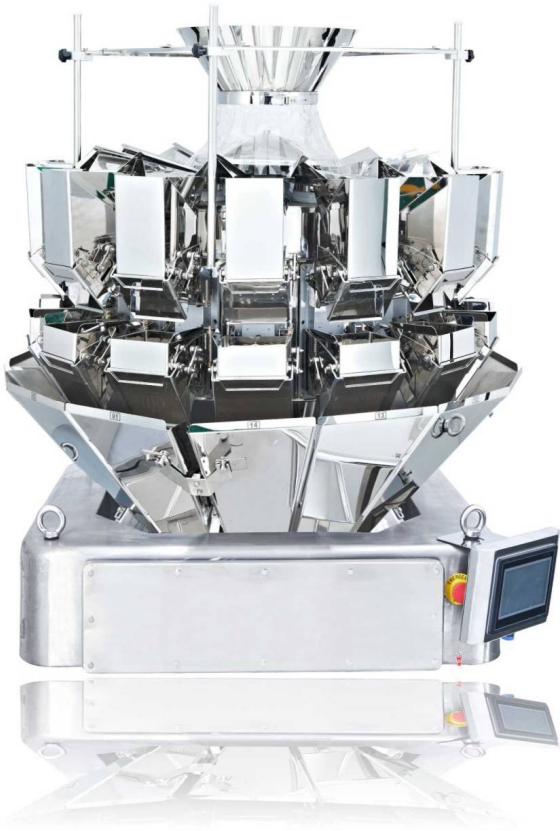

2ND G STANDARD MULTIHEAD WEIGHER



Application

It is suitable for weighing candy, seeds, jelly, pet foods, puffy foods, pistachio, peanuts, nuts, raisins, dried fruits, frozen foods, snack foods, hardwares, meatballs etc.

5. Calibration can be made with 200g and 1000g.
6. Intelligent alarm diagnosis.

Features

1. Modular and CAN bus technology, more efficient and stable.
2. Modbus industry communication protocol.
3. High speed stagger dump function.
4. Online PC monitors function for intelligent management and remote control.

Mechanical Character

1. New designed machine cabinet contributes to more stability.
2. Load cell detection under the top cone.
3. New actuator design reduces the mechanical vibration and improves the load cell value accuracy.
4. Arc-shaped machine body with large R treatment improves the stability and appearance.

Technical Specification

Model	LH-10SW-II	LH-14SW-II
Single Weighing Range	10-1000g	10-1000g
Accuracy	X(0.5)	X(0.5)
Max Speed	65P/M	120P/M
Hopper Volume	3L	
Control Panel	9.7" Touch Screen	
Options	Dimple Plate/Timing Hopper/Printer/Reject Device	
Driving System	Step Motor	
Power Requirement	220V/1500W/50/60HZ/10A	220V/1500W/50/60HZ/11A
Packing Dimension(mm)	1620(L)X1080(W)X1220(H)	1700(L)X1100(W)X1300(H)
Gross Weight	400kg	500kg