

CHEESE WEINGHER

LH PACKAGING BV
http://www.lhpackaging.nl

CHEESE WEINGHER

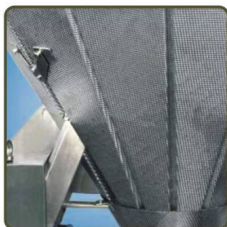

Cheese Weingher

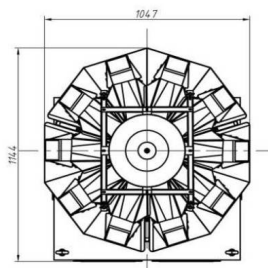
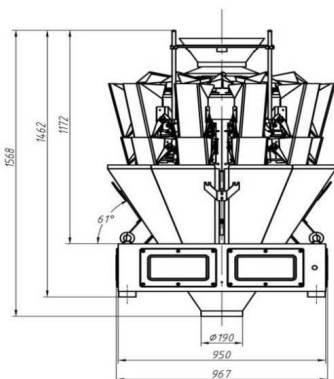

Application

It is suitable for weighing soft and sticky material, such as cheese, jelly, candy etc.

Mechanical Character

1. Enhanced linear vibrator with speed adjustable rotary top cone can make sure of good feeding.
2. 60° discharge chute contributes to less sticky problems.

Features

1. Speed adjustable rotary top cone is suitable for different product feeding.
2. Dimple-plated 60° chute contributes to good discharge process for sticky products.
3. Enhanced linear vibrator improves the flowability of material.

Technical Specification

Technical Specification		
Model	LH-10C-I	LH-14C-I
Single Weighing Range	20-1000g	20-1000g
Accuracy	X(0.5)	X(0.5)
Max Speed	60P/M	100P/M
Hopper Volume	1.6L/2.5L	
Control Panel	7.0" Touch Screen	
Options	Dimple Plate/Timing Hopper/Printer/Reject Device	
Driving System	Step Motor	
Power Requirement	220V/1000W/50/60HZ/10A	220V/1500W/50/60HZ/10A
Packing Dimension(mm)	1620(L)X1100(W)X1110(H)	1700(L)X1110(W)X1130(H)
Gross Weight	380kg	490kg