

MULTI-MOUTH FEEDER WEIGHER

LH PACKAGING BV
http://www.lhpackaging.nl

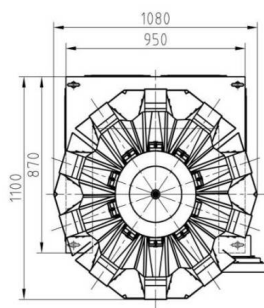

Multi-mouth Feeder Weigher

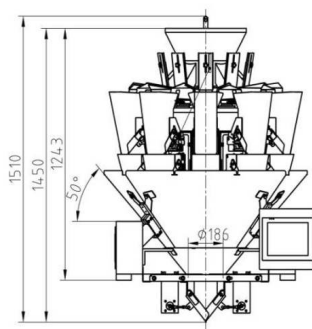
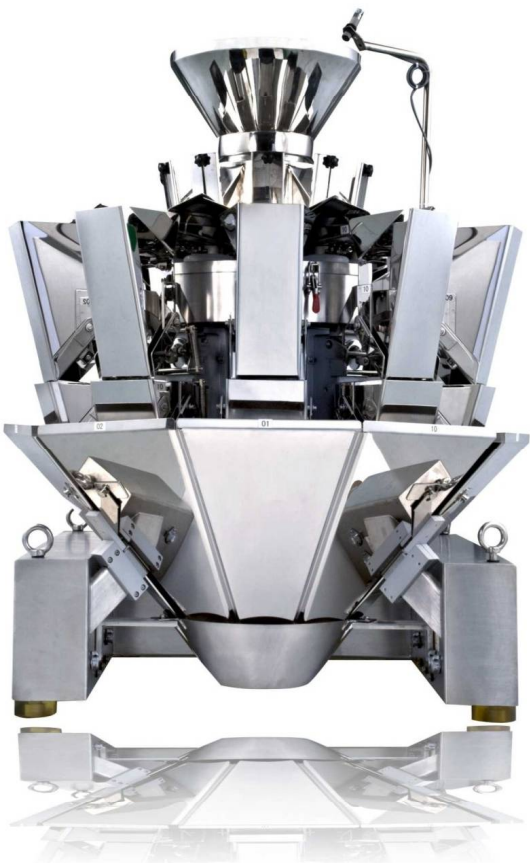

MULTI-MOUTH FEEDER WEIGHER



Application

It is suitable for weighing small granules such as rice, sugar, fine tea, detergent powder, etc.

- 5. 100 programs capacity can meet various weighing requirement.
- 6. Linear amplitude can be adjusted independently.

Features

1. Program recovery function can reduce operation failures.
2. No products auto pause function can improve weighing stability and accuracy.
3. High-precision digital load cell.
4. User-friendly help menu in touch screen contributes to easy operation.

Mechanical Character

1. Multi-mouth feeder can dispense products into each linear feeder pans effectively.
2. U shape linear feeder pans can avoid leaking problem.
3. New tight hoppers with great interchangeability ensures there is no leaking problems during weighing and discharging process.

Technical Specification

Technical Specification		
Model	LH-10MF-I	LH-14MF-I
Single Weighing Range	20-1000g	20-1500g
Accuracy	X(0.5)	X(0.5)
Max Speed	50P/M	80P/M
Hopper Volume	1.6L/2.5L	
Control Panel	7.0" Touch Screen	
Options	Dimple Plate/Timing Hopper/Printer/Reject Device	
Driving System	Step Motor	
Power Requirement	220V/1000W/50/60HZ/10A	220V/1500W/50/60HZ/12A
Packing Dimension(mm)	1620(L)X1100(W)X1110(H)	1700(L)X1110(W)X1130(H)
Gross Weight	380kg	490kg